



ELECTRO SERVO TURRET PUNCH PRESS
全電伺服轉塔式沖床

ES29

台勵福 Tailift

ES29

- ◆ 台勵福全新推出ES-29全電伺服轉塔式沖床，採用全電系列AC伺服數控系統，具有高速、節能、高精度與低噪音的特色，加上過負載自動保護設計，是沖壓高精密薄板件的利器。它的集成式組裝方式，有效減少地面安裝空間。因具有沖孔、成型、滾切與攻牙等多功性能，可減少無效率工時的等待，大大提升加工效率。另外節能方面，平均耗電顯著降低，無液壓油的消耗，是環保保護需求的綠色產品，這也是

Tailift's latest innovation, ES29, AC Servo drive and numerical control technology. Featured with high speed, high precision, energy saving, and low noise.

Equipped with over-load protection, ES29 is an effective implement for thinner sheet metal.

ES29 combined with processing abilities of, punching, forming, roller cutting and tapping, an all-in-one machine. The integration assembly reduces floor space requirements effectively. Low electricity consumption, energy-saving, eliminating the hydraulic. This ECO friendly product is the major milestone form Tailift's R&D.



◆ 機身 Frame

機身基座採O型龍門式架構設計，經世界級頂尖實驗室使用結構有限元素分析後，完成機身機座各部結構之靜性結構分析、剛性結構分析、暫態分析等應力結構性資料。

在構造機身基座之材料上，選用高強度鋼材焊接，引進尖端熱處理技術，消除焊接產生的熱內應力，使機身金屬結構完成統一機身機座，在精加工前更再經過高張力測試、正常化處理與震動應力消除等三道防線嚴格把關，使機身組裝精度維持一致性。

The heart of the Tailift turret punch press is its solid and closed "O" frame structure design. The whole frame is fabricated from premium steel, then through applying ANSYS and other advanced techniques to analyze the internal stress, to minimize such internal and vibration stress from heat treatment.

Consequently, distortions resulting from the punching process are greatly reduced, ensuring a consistent die clearance and long tool life.

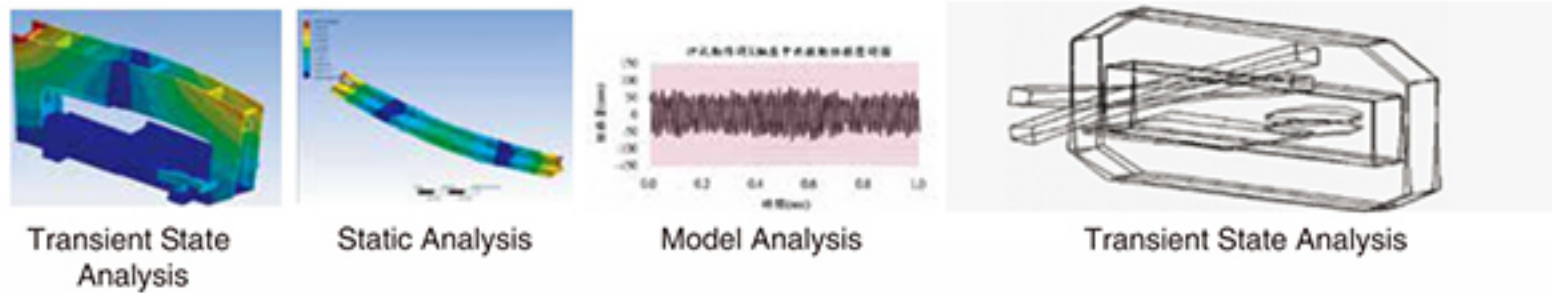

◆ AC伺服數控系統 AC servo electric system

ES29採用的是高階AC伺服馬達，單伺服加曲柄連桿組件，無飛輪蓄能，具有較高的精準度、低噪音環境影響。在沖壓過程中的平均總耗電量是一般油壓機型的一半及無液壓油耗和環保問題。行程及速度可依程式設定達到最佳加工模式，這每年可以節省使用者的消耗成本。

ES29 employs high level AC servo motor in combination with the use of crank type connecting rod without flywheel, leading to higher accuracy and a low noise working environment. In punching operation, its average power consumption is only one-half of comparable hydraulic models and without need of hydraulic fluid as well as no environmental pollution problem. Travel and speed can be set according to programs so as to achieve the optimal machining conditions.

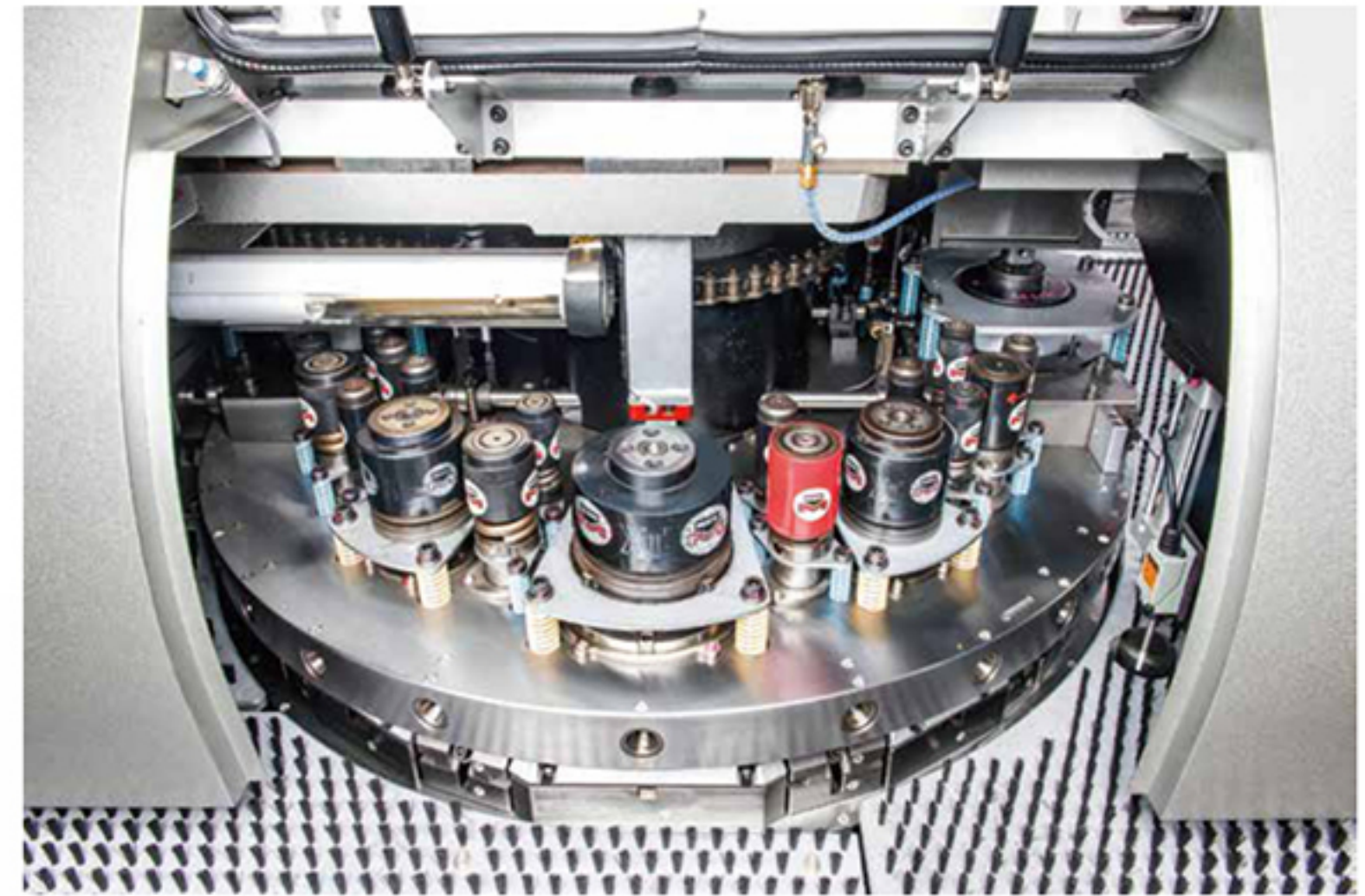

◆ 刀盤 Turret

採用蝸桿蝸輪設計，雙軸同步連桿轉動，定位安全可靠。刀盤擁有40刀站之轉刀盤，搭配" 3 1/2" 尺寸的轉刀，依據客戶加工需要，自行變換刀具。採用通用規格設計，刀盤上各刀站可搭配各廠牌刀具，如Mate·Wilson·另外，刀盤採同心多環式刀盤設計，各刀站均使用高強度耐磨之可替換襯套，維修更方便。

Large turret design with two/three concentric circle tracks available with 40 stations with 2D(3 1/2) type Auto Index.

All stations are compatible with Mate, Wilson or Amada thick turret tools.

Quick and Easy to exchange the tools.

刀盤孔位編號

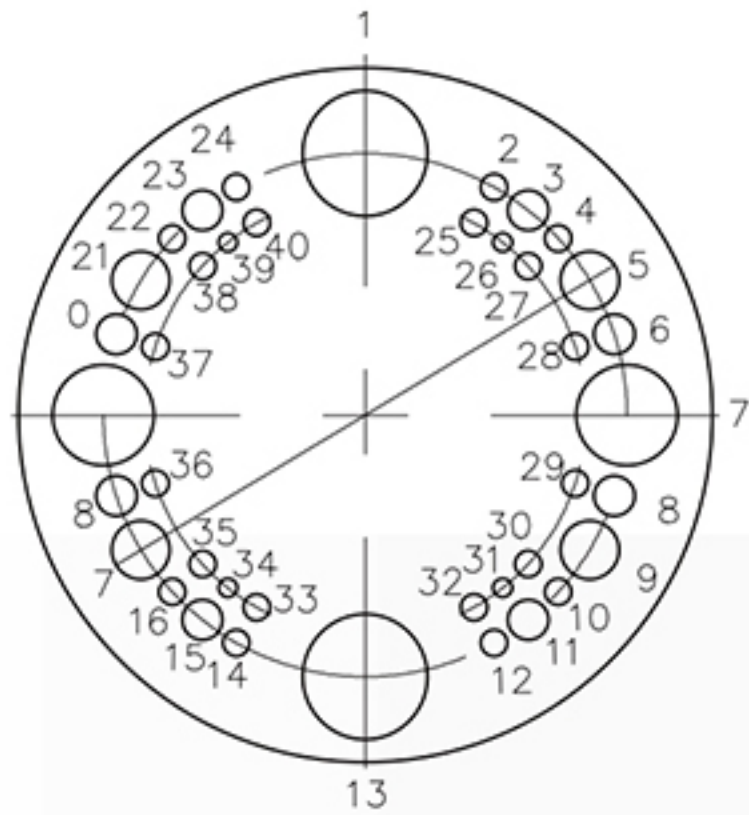

40刀站 stations		
形式	規格	數量
A圓	1/2"	4
A	1/2"	20
B	1-1/4"	8
C	2"	4
E	4-1/2"	2
自動轉刀 Auto Index		
D	3-1/2"	2

◆ 可換式刀站襯套 Replaceable Station Bushing

各刀站均裝配高強度耐磨之可換式襯套，長期使用後無須拆卸整組刀盤，即可輕易保修，縮短保養工時及維修費。

Hardened steel bushings for all tool stations for high precision and durability. Easily replaceable when tool station is damaged.

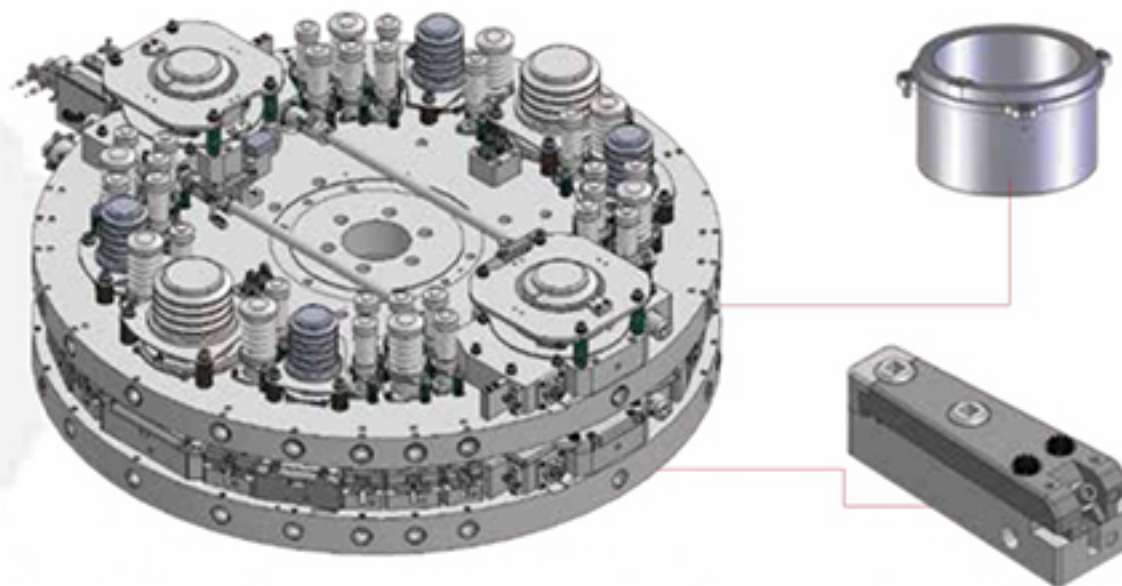

◆ 移動式沖頭 Movable RAM

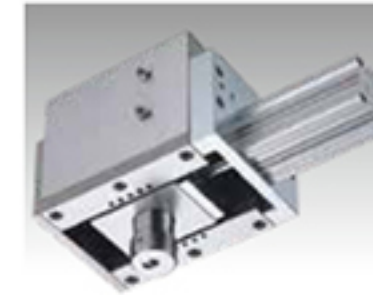

移動式沖頭，配備超載保護裝置，搭配同心多環式刀盤，讓加工更具彈性。

The movable RAM collocated with overloading protector and three concentric circle tool stations. Make performance more flexible.

◆ 換爪壓缸 Reposition Cylinder



換爪壓缸由CNC全程式控制，換爪動作快速精準，確保加工精度。

CNC controlled reposition cylinder, to hold the metal sheet in place during the clamp reposition process. Fast clamp reposition and ensures position accuracy.

◆ 鈹件變形偵測裝置 Sheet Distortion Sensor



鈹件彎曲自動偵測器，在發生鈹材變形時的自動停止裝置，可避免因鈹件變形連帶造成機器與刀具的損壞。

To detect the sheet deformation, pause the machine to protect the turret and tools from the damage caused by deformed sheet.

◆ 鈹件防刮裝置 Sheet Scratch Preventer

大刷毛台面 Large Brush Table



- 降低加工所造成的噪音並減少鈹件刮傷。
- Reducing the noise and prevent the sheet from scratching during operation.

下模座防刮刷毛 Die Holder Brush



- 下模座搭配可替換式刷毛，以減少鈹件刮傷之可能。
- Die holder collocated with brush, to protect the sheet from scratch.



◆ 台珠上升機構 Supporting Ball Set

- 使上料與下料的工作更為輕鬆迅速。
- Support the sheet for smooth loading and unloading.

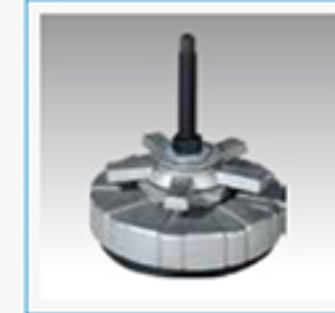

◆ 避震腳墊 Anti-Vibration Foot Mounts

- 與地面層的軟性介面設計，可有效緩衝因X、Y軸頻繁的加減速而產生對滾珠螺桿的衝擊，附有水平調整功能。
- Rubber base interface with floor smoothly and prevent machine from external shock. Equipped with Horizontal machine adjustment.

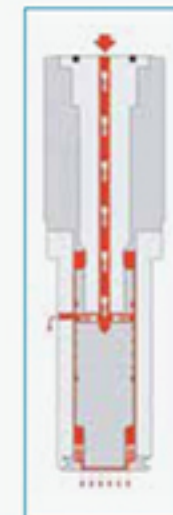

◆ 刀具自動潤滑系統 (選配) Auto Tool Lubrication System

- 可程式控制的油霧系統，提供刀具清潔、冷卻與潤滑，有效提高加工品質並延長刀具壽命
- Programmable air-blow system for tools, cooling and lubrication, to increase tool performance and extend service-life (option).



佔地面積圖 Floor Space



◆ 日本FANUC 控制器 Japanese FANUC Controller

- 新一代FANUC 0i-PF沖床專用高速高精度控制器，搭配全新操作面板設計，服務網遍佈全球，可提供完善快速售後服務。
- New version 0i-PF sophisticated CNC controller with brand-new operator panel. Fanuc worldwide branches can provide fast and complete after-sale service.

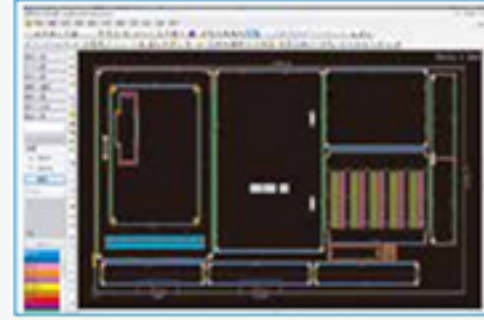

◆ CAD/CAM (選配) CAD/CAM Software

- Windows版操作畫面，可輕易上手，簡化CNC加工程式設計使用。
- Supporting the entire design to production cycle. Advanced technology combines design, processing, graphic simulation and communication in one single module. Create efficient CNC programs with precision and ease (option).

規格表 Specifications

項目 Item	單位 Unit	ES29
沖壓噸數 Punching Capacity	公噸 Ton	30
X 軸行程 X Traverse Length	公厘 mm	2500±10
Y 軸行程 Y Traverse Length	公厘 mm	2000±10
最大加工板件尺寸(含一次換爪) Max Sheet Size (repositioning motions)	公厘 mm	2000×5000
最大加工板件厚度 Max Sheet Thickness	公厘 mm	4.5
工件最大質量 Max Mass of Material	公斤 kg	150
X 軸最大移動速度 X Axis Traverse Speed	米/分鐘 M/min.	80
Y 軸最大移動速度 Y Axis Traverse Speed	米/分鐘 M/min.	70
最大移動速度 Max Traverse Speed	米/分鐘 M/min.	105
S=4mm孔距25mm	下/分鐘 hits/min.	300
營養速度 Nibbling Speed	下/分鐘 hits/min.	600
刀具型式 Tool Type		長刀
沖孔最大孔徑 Max Punching Diameter	公厘 mm	114.3
刀站總數 Number of Tool Stations	支 pcs	40
A(1/2)	支 pcs	24- <20/4(圓)>
B(1-1/4)	支 pcs	8
C(2)	支 pcs	4
E(4-1/2)	支 pcs	2
AI (D3-1/2)	支 pcs	2
刀盤轉數 Turret Rotating Speed	轉/分鐘 rpm	30
自動轉刀轉數 Auto Index Rotating Speed	轉/分鐘 rpm	50
沖錘行程 Ram Stroke Distance	公厘 mm	0~31
工作台型式 Working Table		毛刷/萬向滾球複合檯面
夾爪數 Number of Sheet Clamps	支 pcs	3
電力供應 Power Supply	KVA	40
電壓 Voltage	V	220/380/410/440
氣壓供應 Air Supply	NL/min	5
氣壓壓力 Air Press	bar	5
機器(長度x寬度x高度) Machine Dimensions (LxWxH)	mm	6500×5200×2250
機器概重 Machine Net Weight (Approx)	kg	16000
CNC控制器 CNC Controller		FANUC 0i-PF
傳輸界面 Serial Interface		RS232/RJ45/PCMCIA
定位精度 Punching Precision	公厘 mm	±0.1
重複定位精度 Reposition Accuracy	公厘 mm	0.05
RAM記憶容量 RAM Memory	KB	512

- 產品規格若有變動，恕不另行通知。 Specifications are subjects to change without prior notice.
- X/Y 軸的加速減速依工件的重量而定。 Acceleration / deceleration rate of X / Y-axis are dependent on weight of materials.
- 沖孔速度依不同的加工條件、沖錘行程、加速度及軸的速度而定。 Punch speed depends on processing conditions, stroke length, acceleration / deceleration rate of axes speeds.

Tailift

極致加工，最佳品質。
Ultimate machining; Excellent Quality.



台勵福股份有限公司

台灣總部：台中市大雅區神林路一段269號
Tel : +886-4-25666100
Fax : +886-4-25671670
E-mail: salesgroup@tailiftgroup.com.tw
www.tailiftgroup.com

成功廠：廣州市廣南工業區成功三路170號
Tel : +886-49-2254300
Fax : +886-49-2254302
免付費專線(台灣地區專用)0800-066009

台在機械設備(青島)有限公司

青島本部 山東辦事處
山東省青島膠州市九龍街道辦事處海濱大道海濱工業園
Tel : +86-532-86628399

江蘇辦事處
江蘇省昆山市張浦鎮德地路德地工業園878號5樓1樓北面
Tel : +86-512-50126322
Fax : +86-512-50126324

北京辦事處
河北省滄州市青縣文化街偉業北50米台勵福公司
Tel : +86-317-4229122
Fax : +86-317-4229122

東莞台在機械設備有限公司

廣東省東莞市常平鎮楊村首長科技園台勵福
Tel : +86-769-83219654
Fax : +86-769-83036693



官方微信平台



官方網站