

The Tailift logo features a stylized 'T' composed of three horizontal bars of varying lengths, followed by the word 'ailift' in a bold, white, sans-serif font.

The Pioneer of  
**Fiber Laser Cutting**

# 40000W!!

## Super Laser power

12 M long table 12,000 kW High-Power Laser cutting



**TAILIFT GROUP**  
Fiber Laser Cutting

# TE12025

## TE12025 FLOOR PLAN

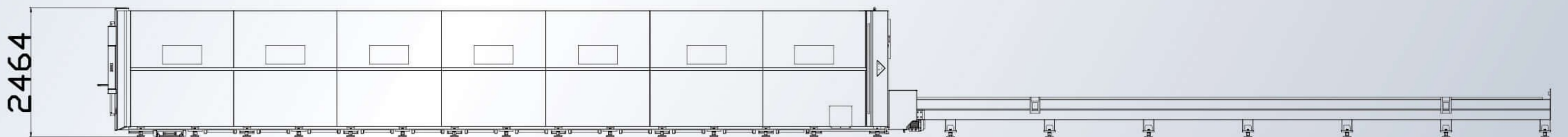
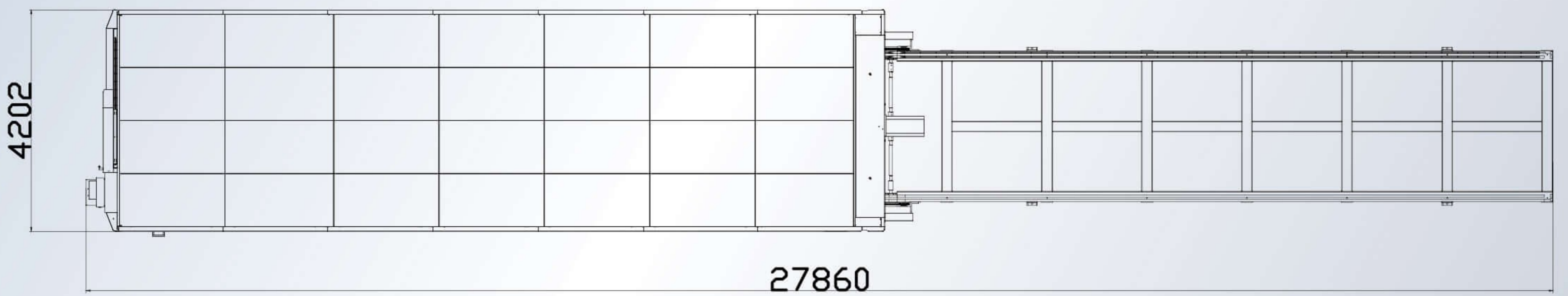
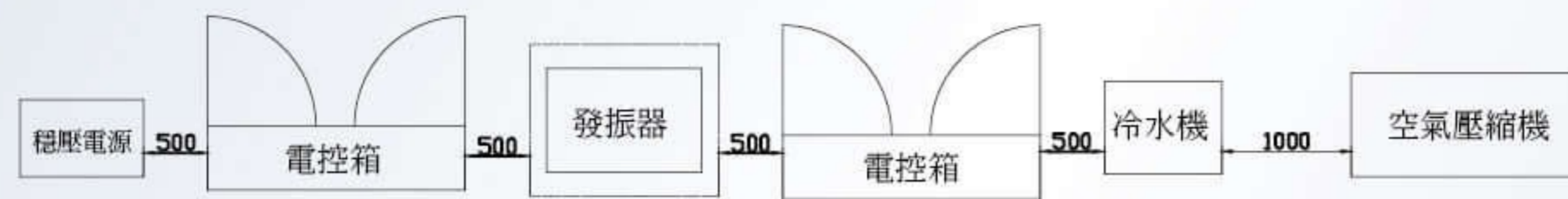

## Specifications

Description	TE12025-12000
Laser power	IPG 12000W~40000W / Raycus 12000W~40000W
Working size	12000x2500mm
X, Y axis Maximum speed	120 m/min
X, Y axis Maximum simultaneous speed	171 m/min
Maximum simultaneous acceleration	2.8g
Positioning Accuracy (1※)	±0.05 mm
Repeat positioning accuracy (1※)	±0.05 mm
Weight	38ton
Dimension	4100x29400x2350 mm
Maximum thickness of processed sheet (2※)	Medium carbon steel ≤40 mm    Stainless steel ≤40 mm    Aluminium ≤40 mm

■ Specifications are subject to change without prior notice.

1※Measuring length 1 m according to VDI/DGQ 3441

2※Sheet cutting accuracy complies with EN ISO-9013

